

# PRODUCT SPEC SHEET

## ALTERA LEVER ACTION ROLL TOWEL SMOKE

**CODE**  
**AG10400**

### GENERAL DESCRIPTION

Lever-operated roll towel dispenser with a roller mechanism that prevents paper jamming. Recommended for high rotation establishments; offices, hospitals, clinics, doctor's offices.

### COMPONENTS AND MATERIALS

- Made of ABS
- Includes installation kit
- Has roller mechanism which prevents paper jamming



### TECHNICAL CHARACTERISTICS

Dimensions in Millimeters	HEIGHT: 365	LENGTH: 280	WIDTH: 285
Dimensions in Inches	HEIGHT: 14.37"	LENGTH: 11.02"	WIDTH: 11.22"
Dimensions in Inches	HEIGHT: 14 3/8"	LENGTH: 11 1/32"	WIDTH: 11 7/32"
Capacity	180 m paper towel roll		
Quantity issued	At convenience		
Weight	2000 grs.	4.40 lb	
Content per box	1 piece		
Finish	Smooth		

### EQUIPMENT CLEANING

A damp cloth is sufficient for cleaning this product. Solvents can dull the piece and erase the silkscreen.

### FUNCTIONING

Operate the lever downwards to dispense the desired paper.

### INSTALLATION

On walls.

VISUALIZATION:

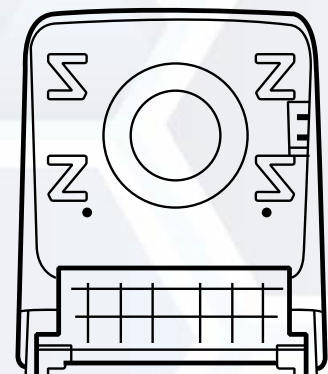
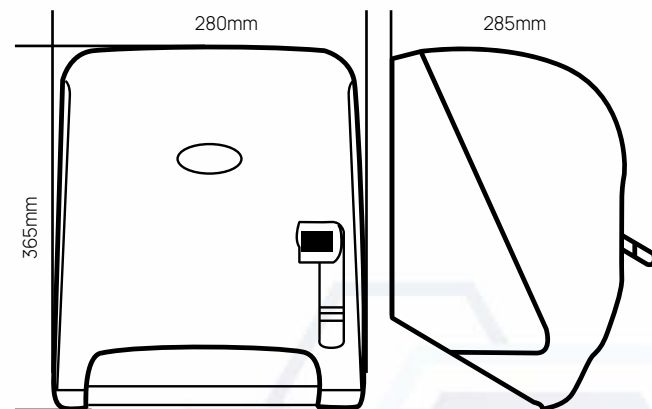

**VALIDATE**

DEPARTMENT OF ENGINEERING  
 AUTHORIZED BY: LAURA LILIA GUERRERO  
 ELABORATED BY: GUADALUPE DE LA LUZ  
 CODE: ING-FO-01  
 FORMAT AND AVAILABLE: ENGINEERING  
 REV-01 VER-01